

ES-855L11/12/13H

5MP IR Eyeball Network Camera



- 1/2.7" 5MP Image Sensor
- H.265+ dual-stream encoding
- IR Effective Range 10~20m
- High quality optical lens 3.6mm/6mm optional
- IVA (Smart Function) Supported
- Multiple Web Browser Supported, IE/Safari/Chrome/Firefox
- P2P Cloud Function By Mobile App (AntarView Pro)
- Lightning Protection Up to 6KV
- IP67 Ingress Protection
- Built-in PoE



System Overview

EZ series 5MP IP cameras are cost efficient solution which is powered by smart H.265+ and advanced cutting-edge image sensor for video monitoring.

It delivers crystal clear images and support industry-leading IVA smart event alarm.

Cloud function is built-in for every single device, which is more convenient and flexible for real time and remote viewing.

Functions

H.265+

Delivering high quality video with up to 70% lower bandwidth. H.265+ is the optimized evolution of H.265 and traditional H.264. The Smart H.265+ includes a series of encoding strategy like Dynamic ROI, smart 2D&3D noise reduction.

IVA (Intelligent Video Analysis)

It allows detecting multiple object behaviors, like Tripwire, Intrusion, Objects Detection, Target Counting etc.

Protection

With precise mechanical and rugged casing design, it stands against water and dust with industrial IP67 rank.

Support $\pm 30\%$ input voltage tolerance, it could work safely in extreme unstable power condition.

With working temperature range -30°C to $+60^{\circ}\text{C}$, it works well in a variety of harsh outdoor environments.

Technical Parameters

Camera

Model	ES-855L11H	ES-855L12H	ES-855L13H	Flash	16MB
Image Sensor	1/2.7" 5MP Image Sensor			S/N Ratio	More than 52dB
Min. Illumination	0.03Lux/F2.0 (color) 0 Lux with IR on			IR Distance	10~20m
Effective Pixels	2560(H)* 1920(V)			IR LED No	1

Lens

Focal Length	2.8mm	3.6mm	6mm	FOV	99.6°	90.5°	60°
Aperture	F2.0						

Video

Compression	H.265/H.264	WDR	DWDR
Resolution	5MP(2560x1920)/1080P(1920x1080)/1.3M(1280x960)/720P(1280x720)/D1(704x576)/CIF(352x288)	Day/Night	Auto(ICR)/Color/B/W
Bit Rate Control	CBR/VBR	White Balance	Supported
Bit Rate	16Kbps-8Mbps	Defog	Supported
Streaming	Dual stream	Noise Reduction	3D DNR
Frame Rate	Main stream: 2560x1920(1~15fps) Sub stream: 704x576(1~25/30fps)	Mirror	Supported
Digital Zoom	12x	Flip	Supported
Audio Compression	G.711u	BLC	N/A
		ROI	N/A
		Anti-flicker	Supported
		Privacy Mask	4 Areas

Alarm & Audio

Video Detection	Motion Detection, Video Shelter,	IVA	Tripwire/Intrusion/Object Left/Missing/Target Counting
Audio	N/A		

Network

Ethernet	1 RJ-45 port(10/100Mbps)	Web Browsers	IE/Firefox/Chrome/Safari
Protocols	TCP/IP, UDP, HTTP, IGMP, ICMP, DHCP, RTP/RTSP/DNS, DDNS, FTP, NTP, PPPoE, UPNP, SMTP, SNMP	VMS	AntarVis 2.0
Onvif	Onvif Profile S	Mobile App	AntarView Pro
Max. Online Users	2	Platform	Mac OS/ Windows/IOS/Android

General

Working Temperature	-30 C ~+60 C	Ingress Protection	IP67
Working Humidity	10~90%	Dimensions	Φ102x93.2mm
Power Supply	PoE, IEEE802.3af DC12V±10%	Net Weight	0.36KG
Power Consumption	<3W	Gross Weight	0.44KG

Ordering Information

Type	Part Number	Description
5MP Camera	ES-855L11H	5MP Network Camera(2.8mm Lens)
	ES-855L12H	5MP Network Camera(3.6mm Lens)
	ES-855L13H	5MP Network Camera(6mm Lens)

Dimensions (mm)

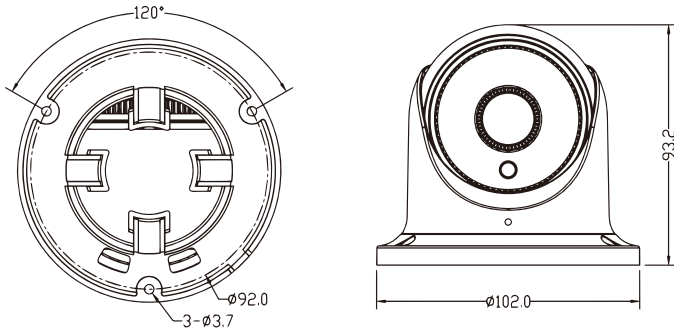

More details

ZKTECO CO.,LTD.
www.zkteco.com
E-mail: sales@zkteco.com

Copyright ©2018 ZKTECO CO., LTD. All rights reserved.

